

These energy efficient In-ground recessed luminaire's are designed to create luminous walkways, or accentuate architecture elements in facades and landscapes providing distinctive lighting effects. Designed for high lumen efficiency at reduced wattage creating exceptional lighting effects.

Product Description

- Luminaire made up of pressure die-cast aluminium & Stainless steel.
- Hard chromeplated stainless steel 316 grade front ring.
- Silicone gasket.
- Toughened clear glass of 8mm thickness.
- Luminaire hard wired with 3 x 0.5mm² cable of 0.5 metre length.
- Supplied with mounting sleeve for preparing recessed opening in ground or wall.
- Cable entries for through-wiring of mains supply cable.
- Integral constant current power supply
- CRI (Ra) : ≥80 (≥90 On Request)
- Prewired with LED driver and suitable for operating on 240V, 50Hz single phase ac supply.
- Ordering guide : KL-4473-CCT (Colour Temperature)
- Available CCT : 2700K, 3000K, 4000K, 6500K



Product Benefits

- High luminous efficiency at reduced wattage.
- A sleek and minimalist shape provides distinctive lighting effects for inground and wall architecture.
- Sustainable LED technology offers durability and optimal light output with low power consumption.

Area of Application

Walk ways, Facades, Landscapes, Architectural elements.

Accessory

- Supplied with IP67 rated connector for a secure connection to the network.
- ABS Plastic outer costing for easy installation.





CITY PARK, JAIPUR



Technical Specifications

General

ID	: 4473
System Wattage	: 12W LED
Driver Integral	: Constant Current
Operating Voltage	: 100-277Vac
Operating Temperature	: -15°C~+50°C

Light Source

Light Source	: CITIZEN COB
CRI (Ra)	: ≥80 (≥90 On Request)
LED Colour Temperature	: 2700K / 3000K / 4000K / 6500K

Physical

Body	: Die-cast Aluminium
Front Ring	: 316 Grade Stainless Steel
Diffuser	: Toughened Clear Glass T=8mm
Louvre	: Honey Comb
Mounting Sleeve	: ABS - Black
Mounting	: Floor - Recess

Driver

Power Supply	: Integral
Input Voltage	: 240Vac
Frequency	: 50-60 Hz
Power Factor	: ≥0.9
THD	: <10%
Surge Protection	: 2.5KV
Efficiency	: >85%

Optical Performance

Beam Angle	: 15° / 25° / 40°
------------	-------------------

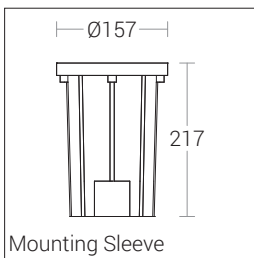
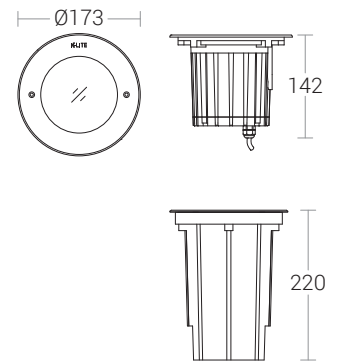

Note : It is our constant endeavor to upgrade the performance of our products. For the latest technical information, IES files and product updates please refer to the website at www.klite.in