

LED compact spot light luminaires designed to provide directional light. The luminaires comes with a connecting cable and an earth spike for portable installation or bracket for permanent installation on a wall, under a ceiling or on a column.

Product Description

- Luminaire made of pressure die cast aluminium alloy of high corrosion resistance and non corrosive stainless steel fasteners.
- Clear toughened glass.
- Mounting earth spike or die-cast aluminium bracket arrangement to facilitate easy installation at any desired location.
- Swivel range of 0°-90°.
- Luminaire supplied with 0.5 metre cable length and a IP67 connector.
- Silicone gasket.
- Prewired with GU10 holder and suitable for operation on 240V, 50Hz single phase ac supply.



Product Benefits

- Sturdy construction in order to maintain performance of the luminaire and to reduce maintenance costs.
- Quick & simple installation.
- Clear glass in the front with continuous rubber gasket to ensure adequate sealing against ingress of moisture, dust, insects etc.,

Areas of Application

Pathways, Parks, Sculptures, Gardens, Structures and Landscape lighting.

Available Finish

- Pure polyester powder coated
- RAL 9004 Signal black
- RAL 9007 Grey aluminium
- RAL 7016 Anthracite grey
- Graphite grey

Accessory



Anti-Glare Visor

Spill Control Snoot

Honey Comb Louvre

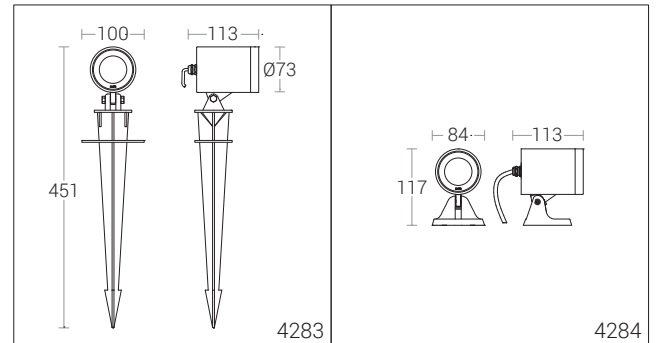
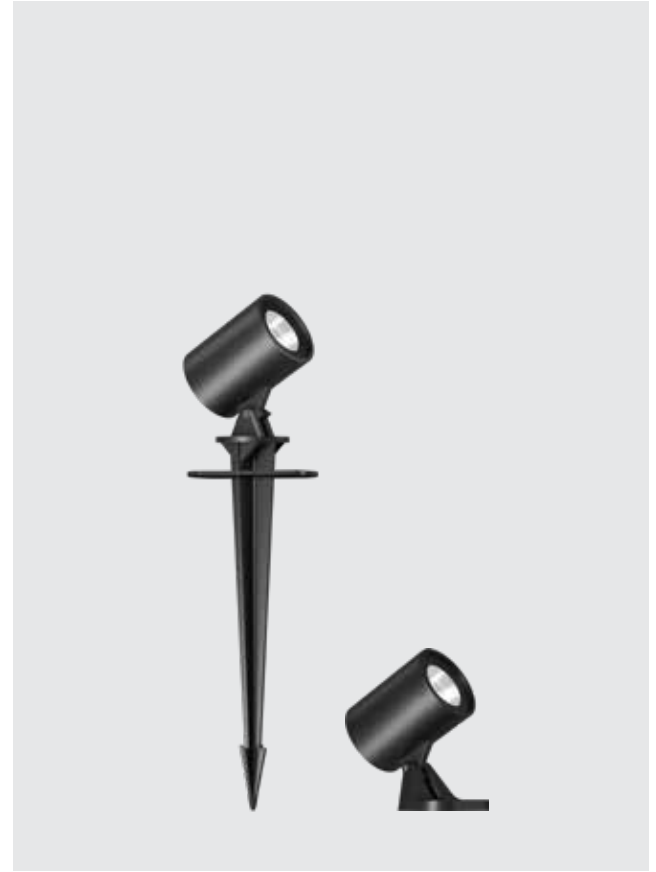

ID	Description	Wattage
4283	Spike	GU10 Holder
4284	Bracket	GU10 Holder